

Serge-André Denis, Product Manager  
Michel Leblanc, Senior Technical Advisor

The recent boom in the deployment of optical broadband networks such as BPOs and GPONs has generated the need for large quantities of specific optical components. These components are expected to be inexpensive, without compromising on quality and performance. Nonetheless, there are different price ranges for components and their cost may sometimes depend largely on the testing that is carried out on them during the manufacturing stage. To remain competitive, component vendors need to find efficient and cost-effective ways to test and qualify key parameters like insertion loss (IL), reflectance and polarization-dependent loss (PDL). For components with large fiber counts – 1XN splitters, for example – optical return loss (ORL) testing can be a major source of inefficiency as some techniques necessitate a lot of handling. This application note reviews and compares two reflectance measurement methods: the traditional optical continuous-wave reflectometry (OCWR) technique and a new mandrel-free technique.

### Optical continuous-wave reflectometry

The OCWR technique is achieved by sending a continuous-wave (CW) optical signal to a device under test (DUT) and measuring the total CW reflected power using a power meter in the return path. Figure 1 shows the block diagram of an OCWR measurement setup.

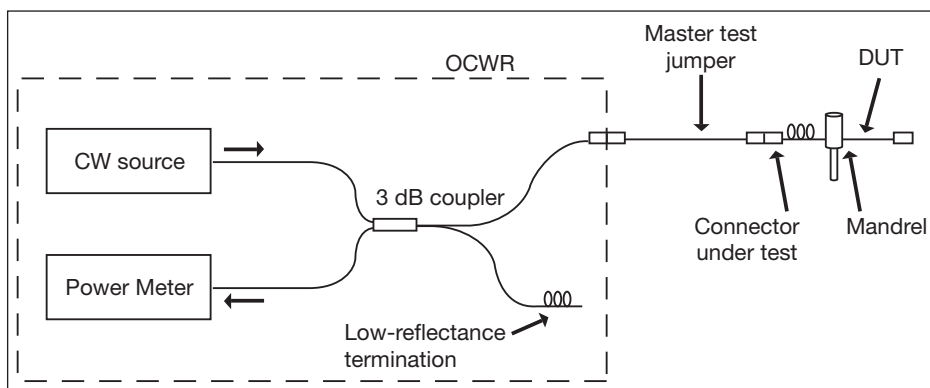

Figure 1. Measurement of a connector reflectance with an OCWR setup.

The measurement sequence implies two steps. The first step is to perform a nulling reference in order to determine the background power level that reaches the power meter, as the power is affected by the following factors:

- Directivity of the 3-dB coupler inside of the OCWR
- Reflectance of the OCWR output port
- Backscattering in the master test jumper (MTJ)

Once the nulling has been performed, the DUT can be tested. Keep in mind, however, that when using the OCWR measurement method a mandrel-wrap is required for both of these steps to ensure proper results (see Figure 2). This technique therefore implies human intervention, as a mandrel-wrap normally consists of wrapping the fiber (the one after the DUT) around a small diameter tool about 10 times.

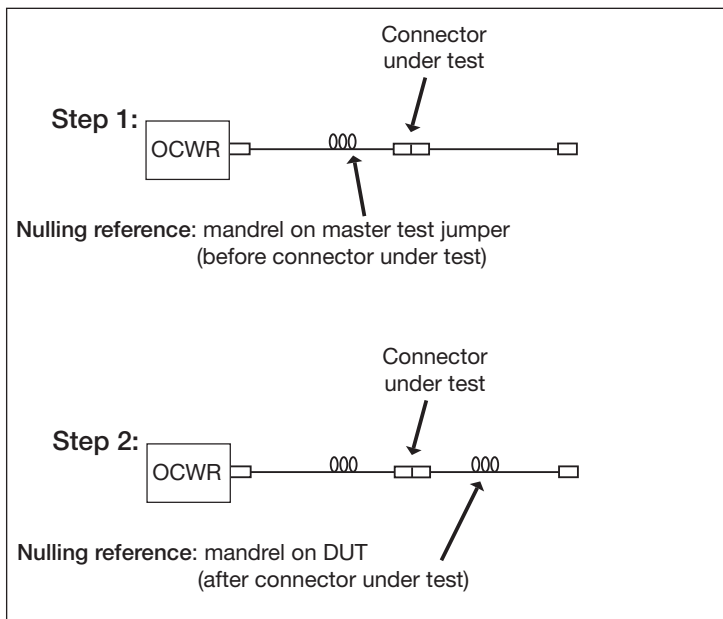

Figure 2. An ORL measurement with an OCWR requires a two-step procedure.

When characterizing components with large fiber counts, like 1XN planar lightwave circuit (PLC) splitters, these manipulations become very time-consuming. For example, in order to test a 1X32 splitter from its common port, 32 mandrels must be applied simultaneously (one for each output port of the splitter; see Figure 3). Most of the splitters, however, are pigtailed with ribbon fiber; an alternative would be to apply a mandrel-wrap at that level. However, ribbon fiber tends to be rigid and fragile, so mandrel-wrapping on those is a risky operation that is not recommended for all types of coating/buffers.

Although the OCWR technique is a simple method that works well when testing patchcords, it is not really practical when dealing with dense splitters such as those used in FTTx systems, where the number of ports may be as high as 32 or even 64.

Moreover, the OCWR technique does not measure discrete reflectance directly; it measures the ORL, which consists of discrete reflectance plus fiber backscattering. To measure the contribution of a particular reflective event, mandrel-wraps need to be applied right before and right after the event, which is not practical when dealing with ribbon fiber or rigid cable. This

restriction limits the ability to measure high-performance components such as those required in FTTx networks. For example, a splitter pigtailed with 3 m of fiber would have an initial return-loss noise floor of 65 dB at 1310 nm, thus limiting the ability to qualify its connectors and/or splitter ports that are typically require reflectance values better than -65 dB.

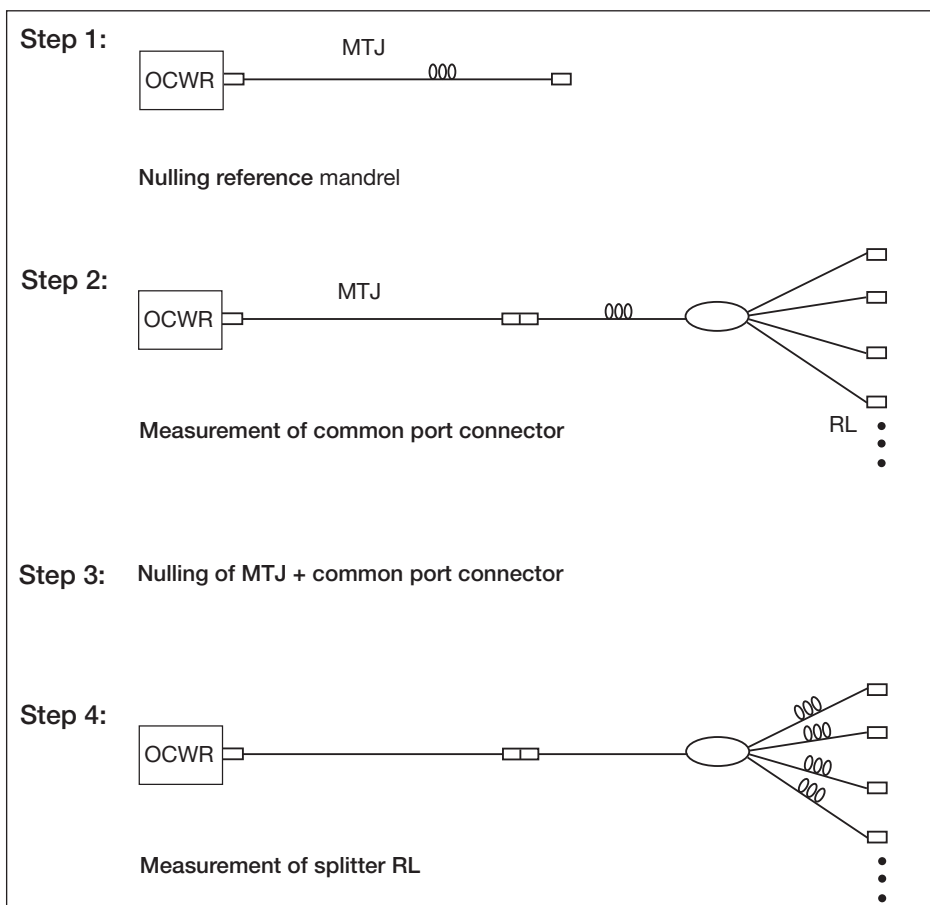
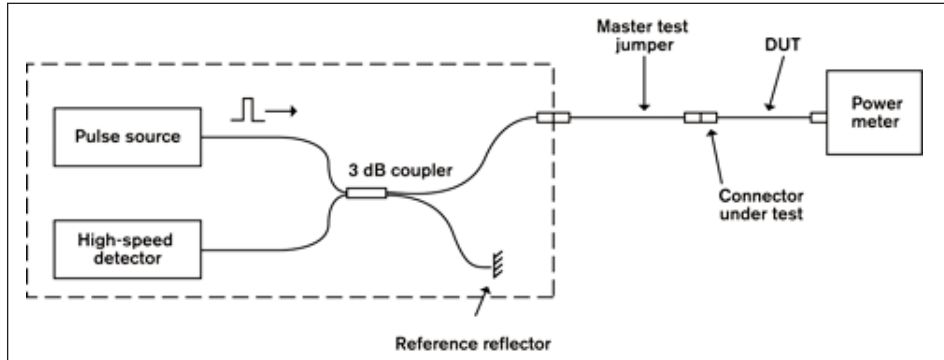

Figure 3. OCWR measurement sequence for a 1XN PLC splitter.

## Mandrel-Free Reflectance Measurements

A few years ago, EXFO developed a mandrel-free reflectance measurement technique to characterize cable assembly IL and reflectance. This approach, which is based on optical time-domain reflectometry (OTDR), allows for precise and repeatable measurement of reflectance and IL in one efficient step (see Figure 4). Our turnkey system, the IQS-12001B, is now widely used in high-volume production by many leading cable assembly manufacturers worldwide.



**Figure 4.** Mandrel-free measurement of a connector IL and reflectance. There is no need to apply any mandrels due to the ability to time-resolve all reflectance components

EXFO's mandrel-free system has now been specially enhanced to support testing of components such as 1XN PLC splitters. The mandrel-free OTDR-based technology greatly simplifies high-fiber-count component testing. The ability of the IQS-12001B to distinguish the different reflective peaks from connectors and splitters allows users to characterize DUTs with a simple and automated test sequence. The mandrel-free reflectance measurement dramatically reduces the total measurement time as no manual operations like mandrels are required (see Figure 5).

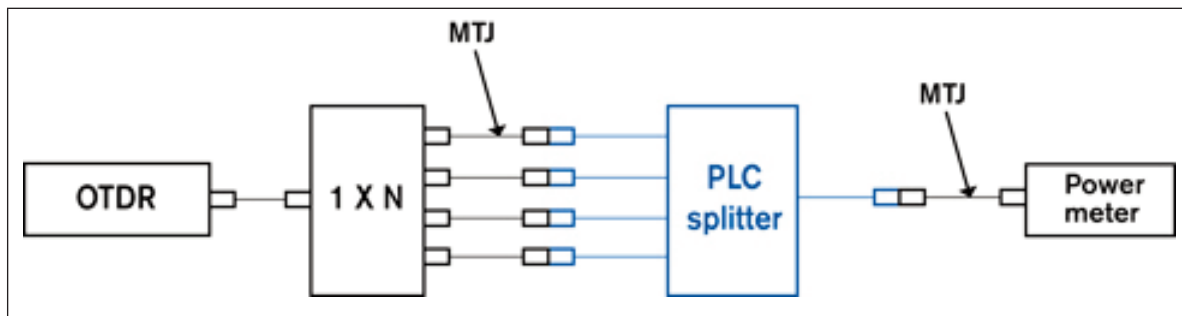

**Figure 5.** Mandrel-free measurement setup for IL and reflectance on an optical splitter. The IQS-12001B uses this configuration to measure the reflectance of each connector as well as the reflectance of the splitter itself at different wavelengths. The system can also measure the IL of each splitter port, and a switch can be used to further increase efficiency, and minimize manual connections and operations.

The IQS-12001B performs reflectance measurement down to -75 dB with very good accuracy and repeatability. The characterization of a PLC splitter can be performed in a single step for each direction tested with the IQS-12001B. In a configuration such as the one shown in Figure 5, a simple sequence allows the user to characterize the input connectors and the splitter reflectance individually as well as measure IL (see Figure 6). The same measurement using the OCWR technique requires three steps per direction and multiple mandrel-wrap operations (1+N mandrels).

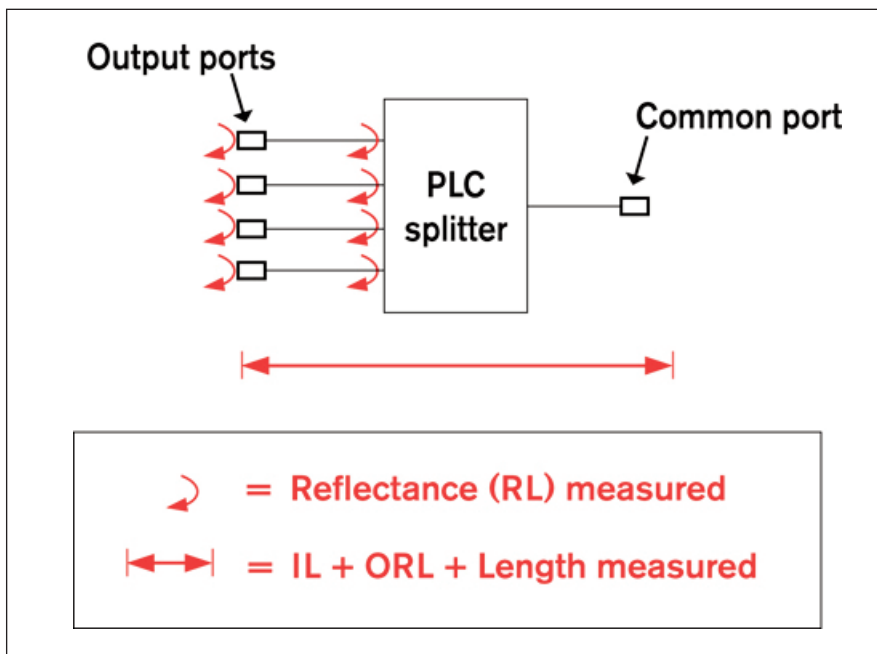

**Figure 6.** In a single and automated sequence, the discrete reflectance of the connector and of the splitter device and its insertion loss (IL) can be precisely characterized simultaneously at four different wavelengths and for any number of ports.

The following table summarizes the benefits of the mandrel-free measurement over the OCWR method:

IQS-12001B mandrel-free technique	OCWR technique
Mandrel-free, simple test sequence.	Requires numerous mandrels and a complex test sequence.
Combines reflectance and IL measurement in one step.	Requires additional handling when both reflectance and IL must be measured for a given component.
Allows for separate characterization of connector and splitter reflectance.	Only provides the overall ORL of the device.
Simple measurement sequence; independent of number of ports.	Measurement sequence complexity grows with number of device ports.
Can be used on all types of pigtail: ribbon fiber, rigid cable, low-bending-loss and multimode fiber.	Difficult (if not impossible) to measure components pigtailed with ribbon fibers, rigid cable, low-bending-loss fiber and multimode fiber.
Reflectance measurement down to -75 dB for any given component or cable assembly length.	ORL measurement typically limited by the backscattering of the device (3 m of fiber = 67 dB of return loss).
Robust measurements and throughputs that do not rely heavily on operator skills.	Highly dependent on operator skills both for accuracy and throughput.

## Conclusion

FTTx deployment has set new heights in terms of optical component performance and volume requirements. Telecom operators now need high-quality optical assemblies that are qualified for return loss beyond 65 dB, all in high volumes and at an affordable price, as these issues directly affect their suppliers. These suppliers, in turn, are looking for efficient and cost-effective ways to test and qualify their products to sustain these requirements.

EXFO's OTDR-based technique, not only allows users to measure discrete reflectance events down to -75 dB, but also automates the testing procedure. This approach, implemented in the IQS-12001B turnkey system, is particularly crucial for high-fiber-count components such as those required in the broadband system market.

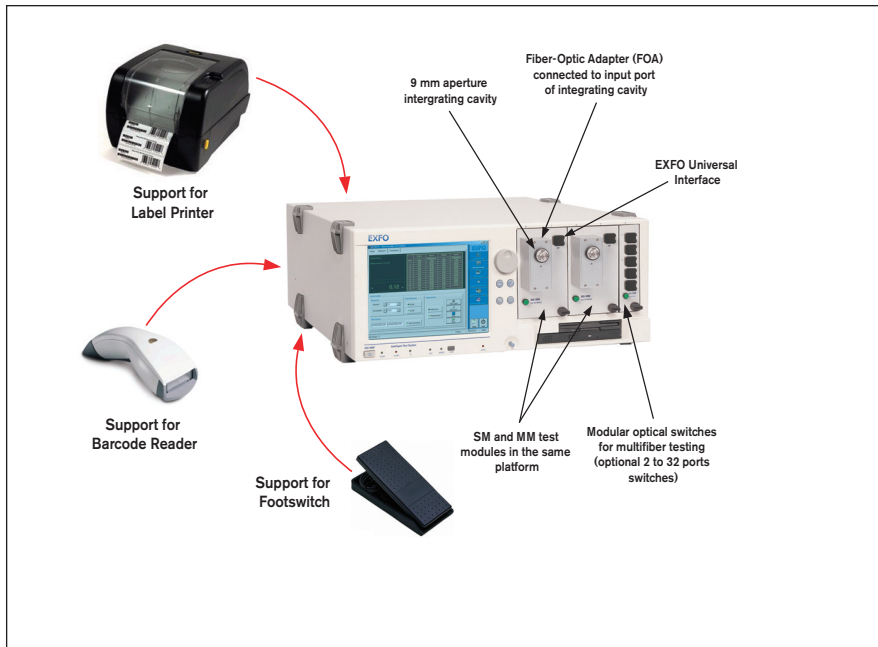

**Figure 6.** IQS-12001B Component and Connector Test System IL, RL and ORL measurement for cable assemblies and optical components

EXFO Corporate Headquarters > 400 Godin Avenue, Quebec City (Quebec) G1M 2K2 CANADA   Tel.: 1 418 683-0211   Fax: 1 418 683-2170   info@EXFO.com				Toll-free: 1 800 663-3936 (USA and Canada)   <a href="http://www.EXFO.com">www.EXFO.com</a>	
EXFO America	3701 Plano Parkway, Suite 160	Plano, TX 75075 USA	Tel.: 1 800 663-3936	Fax: 1 972 836-0164	
EXFO Europe	Omega Enterprise Park, Electron Way	Chandlers Ford, Hampshire S053 4SE ENGLAND	Tel.: +44 2380 246810	Fax: +44 2380 246801	
EXFO Asia	151 Chin Swee Road, #03-29 Manhattan House	SINGAPORE 169876	Tel.: +65 6333 8241	Fax: +65 6333 8242	
EXFO China	No.88 Fuhua First Road	Shenzhen 518048 CHINA	Tel.: +86 (755) 8203 2300	Fax: +86 (755) 8203 2306	
	Central Tower, Room 801, Futian District	Beijing 100044 P.R. CHINA	Tel.: +86 (10) 6849 2738	Fax: +86 (10) 6849 2662	
	Beijing New Century Hotel Office Tower, Room 1754-1755	Beijing 100044 P.R. CHINA	Tel.: +86 (10) 6849 2738	Fax: +86 (10) 6849 2662	
	No. 6 Southern Capital Gym Road				

EXFO is certified ISO 9001 and attests to the quality of these products. This device complies with Part 15 of the FCC Rules. Operation is subject to the following two conditions: (1) this device may not cause harmful interference, and (2) this device must accept any interference received, including interference that may cause undesired operation. EXFO has made every effort to ensure that the information contained in this specification sheet is accurate. All of EXFO's manufactured products are compliant with the European Union's WEEE directive. For more information, please visit [www.EXFO.com/recycle](http://www.EXFO.com/recycle). However, we accept no responsibility for any errors or omissions, and we reserve the right to modify design, characteristics and products at any time without obligation. Units of measurement in this document conform to SI standards and practices.

Contact EXFO for prices and availability or to obtain the phone number of your local EXFO distributor.

For the most recent version of this spec sheet, please go to the EXFO website at <http://www.EXFO.com/specs>

In case of discrepancy, the Web version takes precedence over any printed literature.