

Robert Gendron, System Engineer, Transport and Datacom Business Unit
Amato Gidaro, Product Manager, Transport and Datacom Business Unit

The optical transport network (OTN) was created with the intention of combining the benefits of SONET/SDH technology with the bandwidth expansion capabilities offered by dense wavelength-division multiplexing (DWDM) technology.

In addition to further enhancing the support for operations, administration, maintenance and provisioning (OAM&P) functions of SONET/SDH in DWDM networks, the purpose of the ITU G.709 standard (based on ITU G.872) is three-fold.

First, it defines the optical transport hierarchy of the OTN; second, it defines the functionality of its overhead in support of multiwavelength optical networks; and third, it defines its frame structures, bit rates and formats for mapping client signals.

In order to begin describing the OTN as defined by the ITU G.709 standard, we must first enumerate its critical elements, their termination points, and the way they relate to one another in terms of hierarchy and function.

In essence, the OTN consists of the following parts, which are often referred to as layers:

- Optical Transport Section (OTS)
- Optical Multiplex Section (OMS)
- Optical Channel (OCh)
- Optical Transport Unit (OTU)
- Optical Data Unit (ODU)
- Optical Channel Payload Unit (OPU)

Each of these elements and their functions are distributed along the network and activated when they reach their termination points, which are illustrated in Figure 1 below.

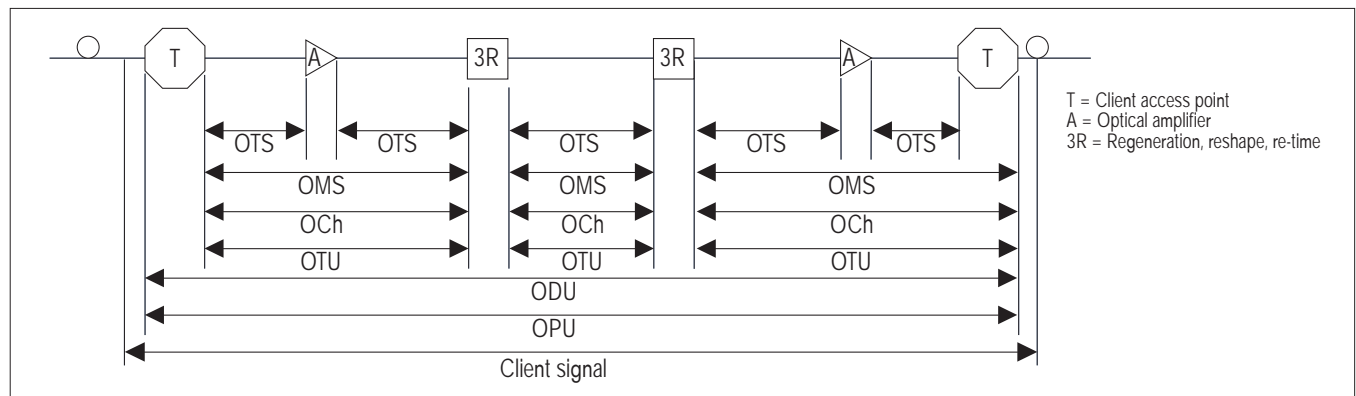

Figure 1: OTN Layer Termination Points

The termination of the OTS, OMS and OCh layers is performed at the optical level of the OTN. It is at the termination of the OTU layer that further functionality can be added. This layer is the digital layer—also known as the “digital wrapper”—and offers specific overhead to manage the OTN’s digital functions. The OTU also introduces a new dimension to optical networking by adding forward error correction (FEC) to the network elements, allowing operators to limit the number of required regenerators used in the network which, in turn, lowers its cost.

FEC allows an increase in the optical link budget by providing a method to correct errors, thereby reducing the impact of network noise and other optical phenomena experienced by the client signal traveling through the network.

As shown in Figure 1, the OTU also encapsulates two additional layers—the ODU and the OPU—which provide access to the payload (SONET, SDH, etc.). These layers are normally terminated at the same location.

The OTU, ODU (including the ODU tandem connection monitoring) and OPU layers can all be analyzed and monitored. As per ITU G.709, the three line rates below are offered, test solutions are currently offered for OTU1 and OTU2:

- OTU1 (255/238 x 2.488 320 Gb/s ≈ 2.666057143 Gb/s) also referred to as 2.7 Gb/s
- OTU2 (255/237 x 9.953280 Gb/s ≈ 10.709225316 Gb/s) also referred to as 10.7 Gb/s
- OTU3 (255/236 x 39.813120 Gb/s ≈ 43.018413559 Gb/s) also referred to as 43 Gb/s

Each line rate is adapted to service different client signals:

- OC-48/STM-16 is transported via OTU1
- OC-192/STM-64 is transported via OTU2
- OC-768/STM-256 is transported via OTU3
- Null Client (All 0s) is transported via OTUk (k = 1, 2, 3)
- PRBS 2³¹⁻¹ is transported via OTUk (k = 1, 2, 3)

In order to map client signals via ITU G.709, they are encapsulated using the structure illustrated in Figure 2.

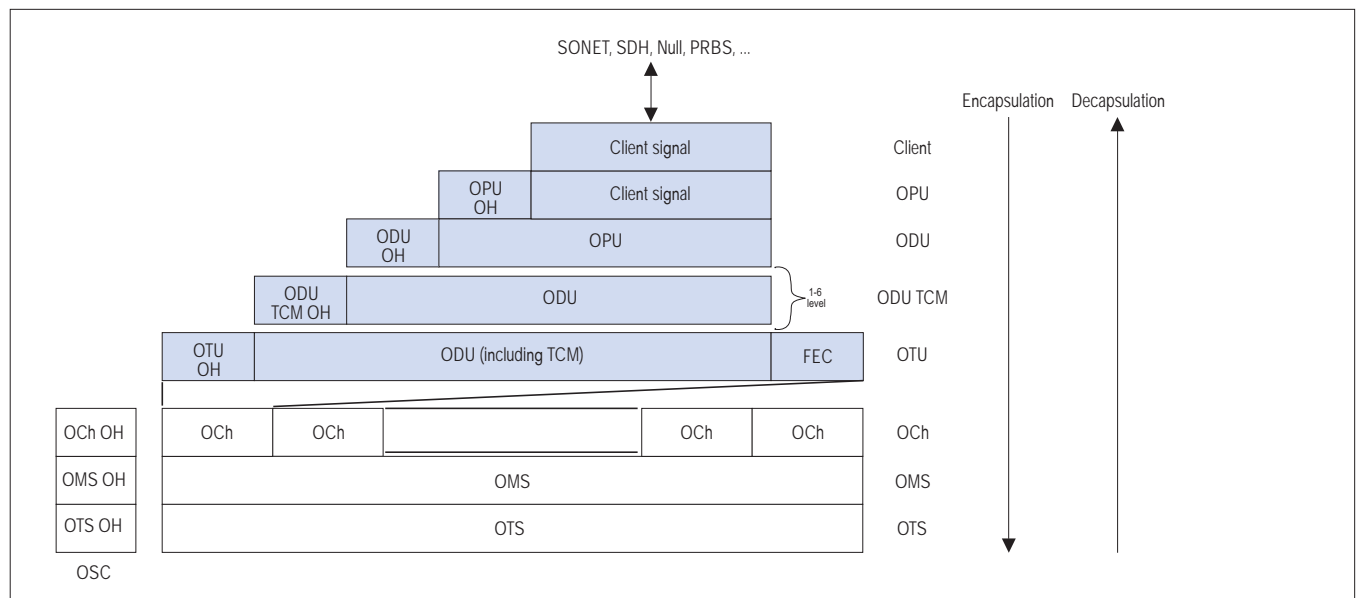

Figure 2: Basic OTN Transport Structure

As depicted above, to create an OTU frame, a client signal rate is first adapted at the OPU layer. The adaptation consists of adjusting the client signal rate to the OPU rate. Its overhead contains information to support the adaptation of the client signal. Once adapted, the OPU is mapped into the ODU. The ODU maps the OPU and adds the overhead necessary to ensure end-to-end supervision and tandem connection monitoring (up to six levels). Finally, the ODU is mapped into an OTU, which provides framing as well as section monitoring and FEC.

Following the OTN structure presented in Figure 2, OTUs (k = 1, 2, 3) are transported using the OCh; each channel is assigned a specific wavelength of the ITU grid. Several channels can be mapped into the OMS and then transported via the OTS layer. The OCh, OMS and OTS layers each have their own overhead for management purposes at the optical level. The overhead of these optical layers is transported outside of the ITU grid in an out-of-band channel called the optical supervisory channel (OSC).

When the OTU frame structure is complete (OPU, ODU and OTU), ITU G.709 provides OAM&P functions that are supported by the overhead.

OTU Frame Structure and Overhead

As shown in the figure below, the OTU frame is broken down into the following components:

- Framing
- OTU, ODU, OPU overhead
- TCM
- OTU FEC

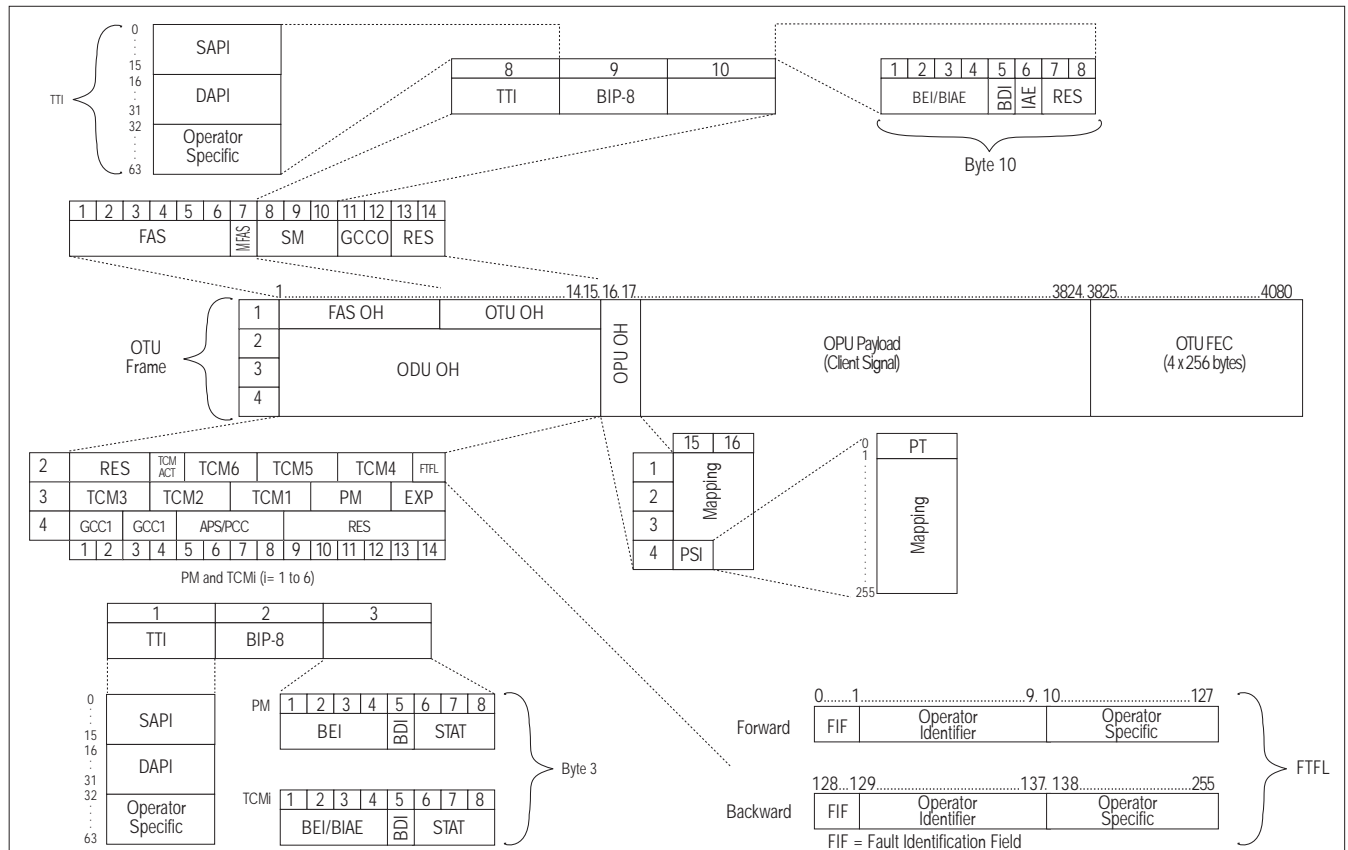

Figure 3: OTU Frame Description

Framing

The OTU framing is divided into two portions: FAS and MFAS.

- The frame alignment signal (**FAS**) uses the first six bytes and, similarly to SONET/SDH, it is used to provide framing for the entire signal. In order to provide enough 1/0 transitions for synchronization, scrambling is used over the entire OTU frame, except for the FAS bytes.
- The multiframe alignment signal (**MFAS**) byte is used to extend command and management functions over several frames. The MFAS counts from 0 to 255, providing a 256 multiframe structure.

Overhead

Each portion of the OTU frame has its own specific overhead functions. They are displayed in Figure 3 and are briefly described below. Further details can be found about these overhead fields in the ITU G.709 standard.

Optical Transport Unit (OTU)

The OTU overhead is comprised of the SM, GCC0 and RES bytes.

- The section monitoring (**SM**) bytes are used for the trail trace identifier (TTI), parity (BIP-8) and the backward error indicator (BEI), or backward incoming alignment error (BIAE), backward defect indicator (BDI), and incoming alignment error (IAE). The TTI is distributed over the multiframe and is 64 bytes in length. It is repeated four times over the multiframe.
- General communication channel 0 (**GCC0**) is a clear channel used for transmission of information between OTU termination points.
- The reserved (**RES**) bytes are currently undefined in the standard.

Optical Data Unit (ODU)

The ODU overhead is broken into several fields: RES, PM, TCMi, TCM ACT, FTFL, EXP, GCC1/GCC2 and APS/PCC.

- The reserved (**RES**) bytes are undefined and are set aside for future applications.
- The path monitoring (**PM**) field is similar to the SM field described above. It contains the TTI, BIP-8, BEI, BDI and Status (STAT) sub-fields.
- There are six tandem connection monitoring (**TCMi**) fields that define the ODU TCM sub-layer, each containing TTI, BIP-8, BEI/BIAE, BDI and STAT sub-fields associated to each TCM level (i=1 to 6). The STAT sub-field is used in the PM and TCMi fields to provide an indication of the presence or absence of maintenance signals.
- The tandem connection monitoring activation/deactivation (**TCM ACT**) field is currently undefined in the standards.
- The fault type and fault location reporting communication channel (**FTFL**) field is used to create a message spread over a 256-byte multiframe. It provides the ability to send forward and backward path-level fault indications.
- The experimental (**EXP**) field is a field that is not subject to standards and is available for network operator applications.
- General communication channels 1 and 2 (**GCC1/GCC2**) fields are very similar to the GCC0 field except that each channel is available in the ODU.
- The automatic protection switching and protection communication channel (APS/PCC) supports up to eight levels of nested APS/PCC signals, which are associated to a dedicated-connection monitoring level depending on the value of the multiframe.

Optical Payload Unit (OPU)

The primary overhead field associated with the OPU is the payload structure identifier (PSI). This is a 256-byte multiframe whose first byte is defined as the payload type (PT). The remaining 255 bytes are currently reserved.

The other fields in the OPU overhead are dependent on the mapping capabilities associated to the OPU. For an asynchronous mapping (the client signal and OPU clock are different) justification control (JC) bytes are available to

compensate for clock rate differences. For a purely synchronous mapping (client source and OPU clock are the same), the JC bytes become reserved. Further details on mapping are available in ITU G.709.

Tandem Connection Monitoring (TCM)

TCM enables the user and its signal carriers to monitor the quality of the traffic that is transported between segments or connections in the network. SONET/SDH allowed a single level of TCM to be configured, while ITU G.709 allows six levels of tandem connection monitoring to be configured. The assignment of monitored connections is currently a manual process that involves an understanding between the different parties. There are various types of monitored connection topologies: cascaded, nested and overlapping. Examples of these topologies are provided in Figure 4.

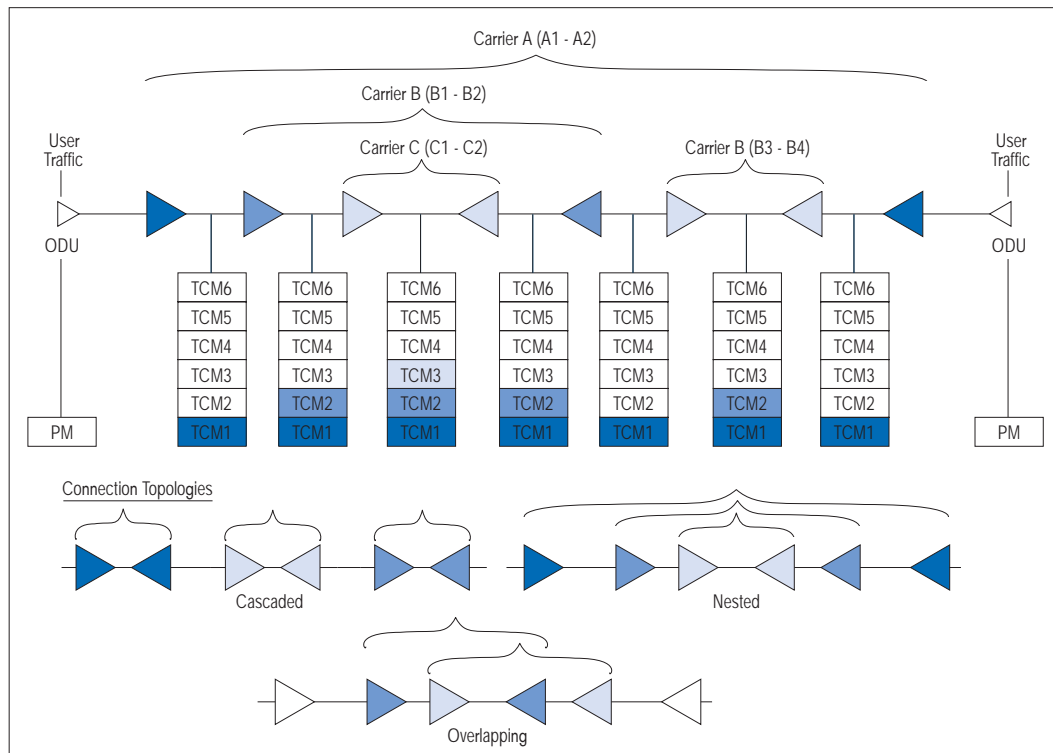

Figure 4: Tandem Connection Monitoring

Each of the six TCM_i fields in the ODU overhead is assigned to a monitored connection. There can be from zero to six levels or connections that can be configured for each ODU trail. In the Figure 4 example, there are three different levels that are actually monitored. Carrier C, due to its location, can monitor three TCM levels as the ODU passes through its portion of the network. The other carriers also monitor the levels according to agreement and location.

In addition to monitoring maintenance signals, using the STAT sub-field associated with each TCM level, the TCM connection also monitors the BIP-8 and BEI errors for each connection level. Maintenance signals are used to advertise upstream maintenance conditions affecting the traffic; errors, on the other hand, provide an indication of the quality of service offered at each segment of the network, which delivers a valuable tool for the user and carrier to isolate faulty sections of the network.

Forward Error Correction (FEC)

The ITU G.709 standard supports forward error correction (FEC) in the OTU frame and is the last part added to the frame before the frame is scrambled. FEC provides a method to significantly reduce the number of transmitted errors due to noise, as well as other optical phenomena that occur at high transmission speeds. This enables providers to support longer spans in between optical repeaters.

An OTU frame is divided into four rows. Each row is broken down into 16 sub-rows comprised of 255 bytes each, as shown in Figure 5. A sub-row is composed of interleaved bytes. The interleave is executed so that the first sub-row contains the first overhead (OH) byte, the first payload byte and the first FEC byte, and so on for the remaining sub-rows of each row in the frame. The first FEC byte starts at position 240 for all sub-rows.

The FEC uses a Reed-Solomon RS (255/239) coding technique. This means that 239 bytes are required to compute a 16-byte parity check. The FEC can correct up to eight (bytes) errors per sub-row (codeword) or detect up to 16 byte errors without correcting any. Combined with the byte interleave capability included in ITU G.709 implementation, the FEC is more resilient to error burst, where up to 128 consecutive bytes can be corrected per OTU frame row.

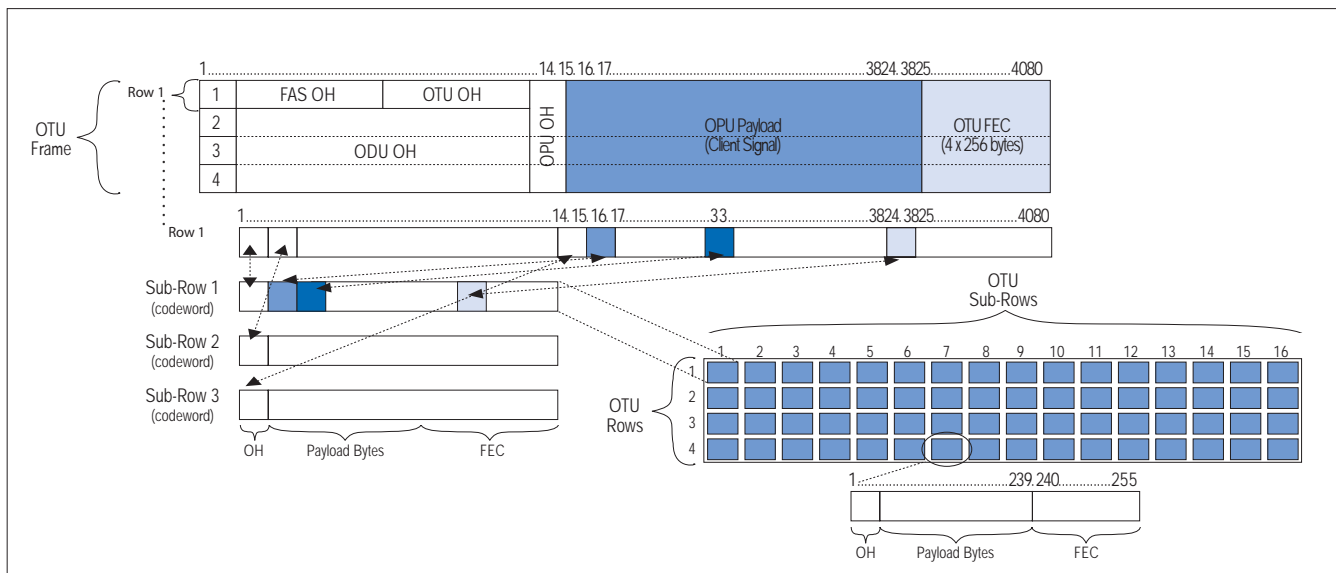

Figure 5: Forward Error Correction

Conclusion

It is expected that the G.709-based OTN will greatly improve administration, maintenance and provisioning operations on DWDM networks and ultimately provide superior transmission.

Of course, as with every type of network, testing always ensures optimum performance. Among the aspects that should be tested in order for OTN equipment to comply with ITU G.709 and ITU G.798 are the following:

— Interface specifications

The interface specification tests consist in determining that the appropriate OTUk rates are supported and that synchronization recovery can be properly achieved by the DUT. Additional tests like optical-power sensitivity can also be achieved using external equipment (optical attenuator).

— Response of the device under test (DUT)

The DUT response test allows the user to use a stimulus (error or alarm) and detect from the test equipment that a DUT is responding with the proper consequential actions for the injected errors or alarm.

— ITU conformance and interoperability

ITU conformance and interoperability relates to the ability to determine that the DUT is able to detect various events under the correct stimulus and standard specified period of time.

— Mapping/demapping of client signals

The mapping/demapping of client signals enable the test equipment to determine if the DUT correctly recovers the OPU payload under the synchronous and asynchronous mapping specifications in terms of required frequency offset tolerance.

— Appropriate FEC behavior

In order to determine the appropriate FEC behavior of a DUT, the test equipment generates correctable or uncorrectable FEC errors and determines if traffic errors are detected. In a basic test, correctable or uncorrectable FEC errors are distributed over the FEC portion of the frame. This facilitates the discovery of unexpected behavior without affecting the traffic, thus building a confidence level in the FEC under test. As the risk is reduced, additional FEC stress tests can be conducted on the signal by distributing, at random and over the entire OTU frame, correctable errors that should be recovered by the DUT. This time, if the DUT is unable to correct errors, the payload will be affected.

The ITU G.709 testing standard is supported by the EXFO FTB-8120/FTB-8130 or IQS-8120/IQS-8130 modules. For further insight on their ITU G.709 testing capabilities we invite you to consult their respective specification sheets. In the meantime, we hope this application note succeeded in providing a broad description of the optical transport network and the standards governing it.

References

- [1] ITU Recommendation G.709/Y.1331, *Interfaces for the Optical Transport Network (OTN)*, March 2003 (Amendment1 December 2003)
- [2] ITU Recommendation G.798, *Characteristics of optical transport network hierarchy equipment functional blocks*, June 2004 (Erratum 1 May 2005)
- [3] ITU Recommendation G.872, *Architecture of optical transport networks*, November 2001 (Amendment1 December 2003, Corrigendum 1 January 2005)

EXFO Corporate Headquarters > 400 Godin Avenue, Quebec City (Quebec) G1M 2K2 CANADA | Tel.: 1 418 683-0211 | Fax: 1 418 683-2170 | info@EXFO.com

Toll-free: 1 800 663-3936 (USA and Canada) | www.EXFO.com

EXFO Montreal	2650 Marie-Curie	St-Laurent (Quebec) H4S 2C3 CANADA	Tel.: 1 514 856-2222	Fax: 1 514 856-2232
EXFO Toronto	160 Drumlin Circle	Concord (Ontario) L4K 3E5 CANADA	Tel.: 1 905 738-3741	Fax: 1 905 738-3712
EXFO America	3701 Plano Parkway, Suite 160	Plano, TX 75075 USA	Tel.: 1 800 663-3936	Fax: 1 972 836-0164
EXFO Europe	Omega Enterprise Park, Electron Way	Chandlers Ford, Hampshire S053 4SE ENGLAND	Tel.: +44 2380 246810	Fax: +44 2380 246801
EXFO Asia	151 Chin Swee Road, #03-29 Manhattan House	SINGAPORE 169876	Tel.: +65 6333 8241	Fax: +65 6333 8242
EXFO China	No.88 Fuhua, First Road Central Tower, Room 801, Futian District	Shenzhen 518048, CHINA	Tel.: +86 (755) 8203 2300	Fax: +86 (755) 8203 2306
	Beijing New Century Hotel Office Tower, Room 1754-1755 No. 6 Southern Capital Gym Road	Beijing 100044 P. R. CHINA	Tel.: +86 (10) 6849 2738	Fax: +86 (10) 6849 2662