

ORL TESTING OF 16-CHANNEL THIN-FILM MULTIPLEXER/DEMULTIPLEXER

Michael Carlson, Marketing Manager, Passive Component Testing Group, EXFO Electro-Optical Engineering Inc.

Abstract

A 200 GHz 16-channel thin-film device was tested using a tunable laser-based measurement system for spectral dependence of the optical return loss. The device was tested in both directions, as a multiplexer (MUX) and as a demultiplexer (DEMUX) using the IQS-12004B system, and the results were compared. Significant structure was found in the optical return loss of the device, which proves the necessity of performing spectral optical return loss (ORL) measurements for similar components.

Introduction

The sample was tested using the EXFO IQS-12004B DWDM Passive Component Test System.

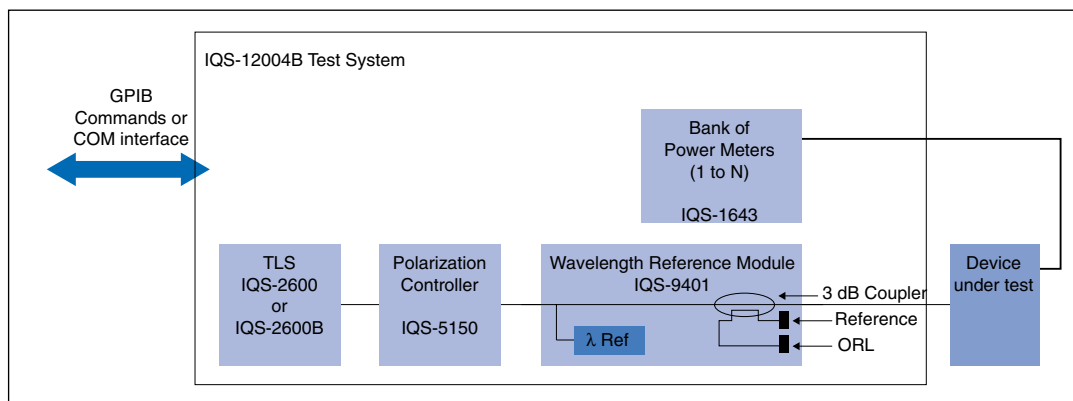

Figure 1. Typical IQS-12004B setup

The IQS-12004B system is designed to provide fast and accurate high-resolution characterization of DWDM passive components. The system is based on a sweeping, medium-coherence tunable laser source along with multichannel optical power meters. The system's wavelength accuracy is provided using reference optical components in an instrument known as the wavelength reference module. An optional polarization state adjuster is also offered for performing Mueller Matrix polarization-dependent loss (PDL) measurements.

The technique for measuring ORL is a variation of optical continuous wave reflectometry (OCWR), where a tunable laser source is used instead of a fixed laser source. The medium-coherence tunable laser is particularly suitable for ORL measurements. Medium coherence is important in order to prevent the optical interference of parasitic etalons from masking the actual measurement structure. To ensure the thoroughness of the procedure, insertion loss (IL) and PDL measurements were also performed on the sample.

Insertion Loss Measurement

The sample's insertion loss was measured by using it as a demultiplexer, connected as shown in Figure 2.

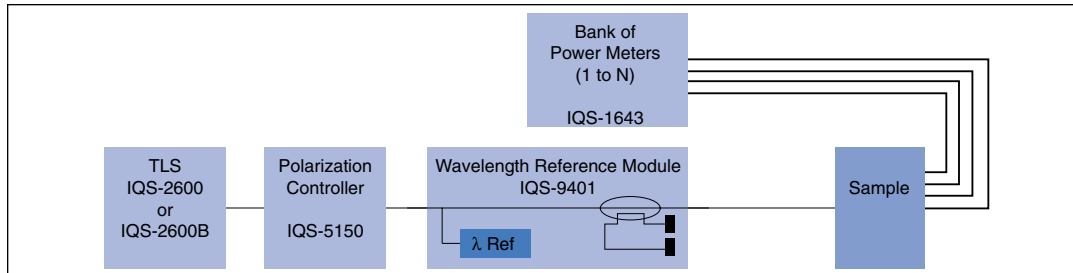

Figure 2. IL Setup with sample used as a MUX

In this configuration, all channels are tested at the same time. The spectral profile is shown in Figure 3. The IL measurements were performed at the same time as the PDL measurements; the IL shown in Figure 3 is the average IL calculated in accordance with Mueller Matrix algorithms.

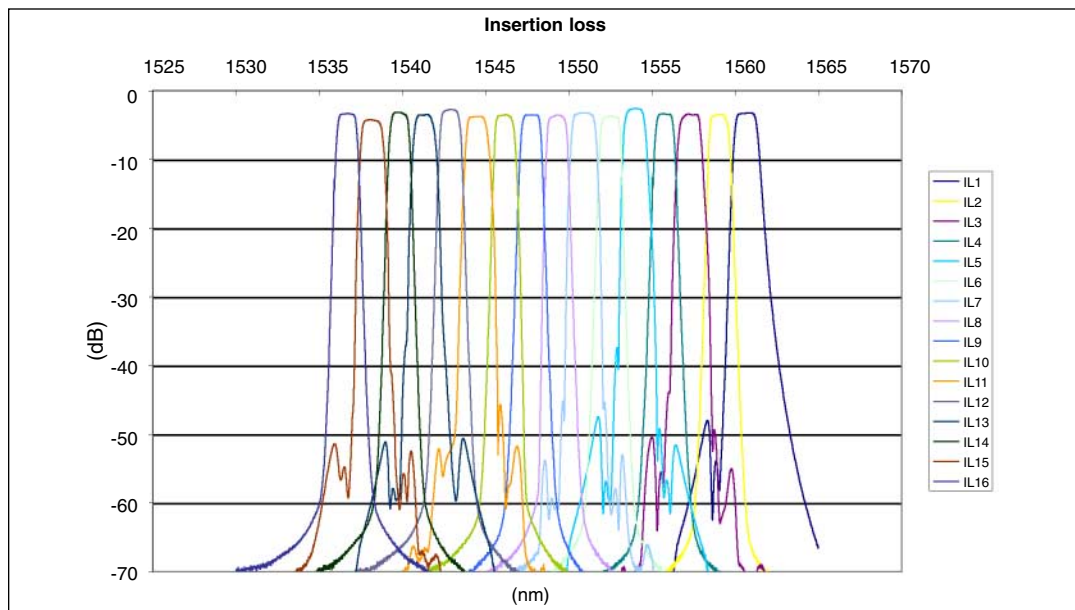

Figure 3. Spectral profile with average IL

Polarization-Dependent Loss

The PDL of each channel was also measured with the sample connected as a demultiplexer. The PDL is calculated based on four scans at orthogonal states of polarization, using Mueller Matrix algorithms. The table below includes the PDL at the central wavelength as well as other interpreted data.

The PDL indicated in the table is the value at the central wavelength for each channel. Complete PDL data is available as a function of wavelength. Channel 1 results are shown in Figure 4.

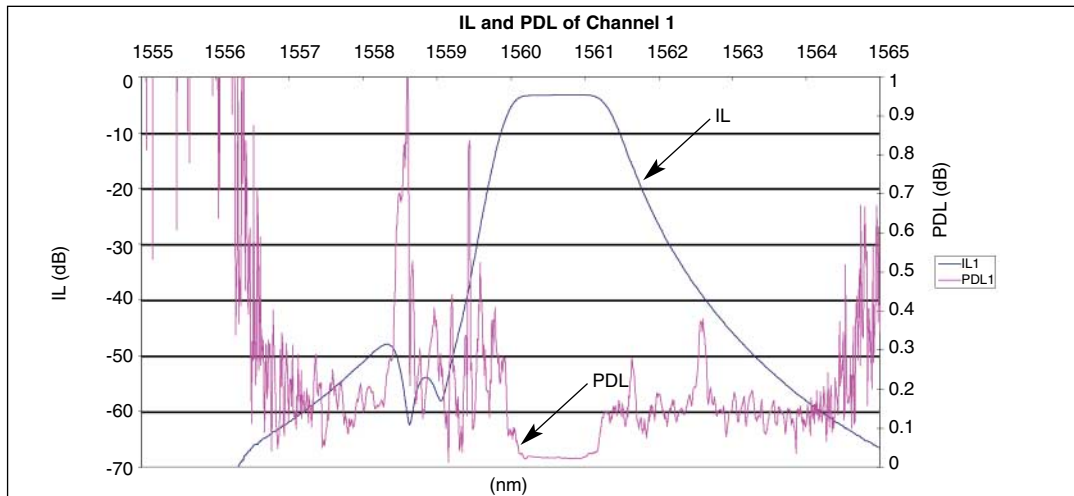

Figure 4. Typical results for devices with low PDL in passband

Optical Return Loss Measurements

The ORL of the sample was tested in two different configurations, as a demultiplexer and as a multiplexer.

	CH1	CH2	CH3	CH4	CH5	CH6	CH7	CH8
Measured Wavelength (nm)	1560.65	1559.008	1557.3	1555.769	1553.96	1552.507	1550.896	1549.293
Insertion Loss (dB)	4.238	4.453	4.422	4.33	3.609	4.704	4.221	4.523
BW1: at 1.00 dB (nm)	1.154	0.959	1.077	0.915	1.023	1.032	1.235	0.996
BW2: at 3.00 dB (nm)	1.369	1.163	1.308	1.096	1.256	1.195	1.433	1.179
BW3: at 20.00 dB (nm)	2.239	1.743	2.065	1.693	1.934	1.713	2.005	1.686
Maximum Crosstalk (dB)	29.93	27.62	23.71	29.43	28.86	26.21	31.52	27.89
PDL ITU (dB)	0.025	0.056	0.043	0.03	0.065	0.036	0.012	0.084
Mask Type	Bandpass	Bandpass	Bandpass	Bandpass	Bandpass	Bandpass	Bandpass	Bandpass
	CH9	CH10	CH11	CH12	CH13	CH14	CH15	CH16
Measured Wavelength (nm)	1547.738	1546.129	1544.468	1542.877	1541.315	1539.836	1538.156	1536.664
Insertion Loss (dB)	4.531	4.511	4.734	3.71	4.453	4.138	5.224	4.299
BW1: at 1.00 dB (nm)	1.008	0.964	1.057	0.985	0.974	0.944	1.097	1.026
BW2: at 3.00 dB (nm)	1.177	1.155	1.28	1.187	1.26	1.148	1.311	1.195
BW3: at 20.00 dB (nm)	1.741	1.727	2.027	1.751	1.912	1.718	1.9	1.765
Maximum Crosstalk (dB)	35.37	37.98	29.82	31.65	28.92	30.17	25.08	24.24
PDL ITU (dB)	0.04	0.06	0.079	0.046	0.048	0.062	0.032	0.027
Mask Type	Bandpass	Bandpass	Bandpass	Bandpass	Bandpass	Bandpass	Bandpass	Bandpass

Demultiplexer ORL Results

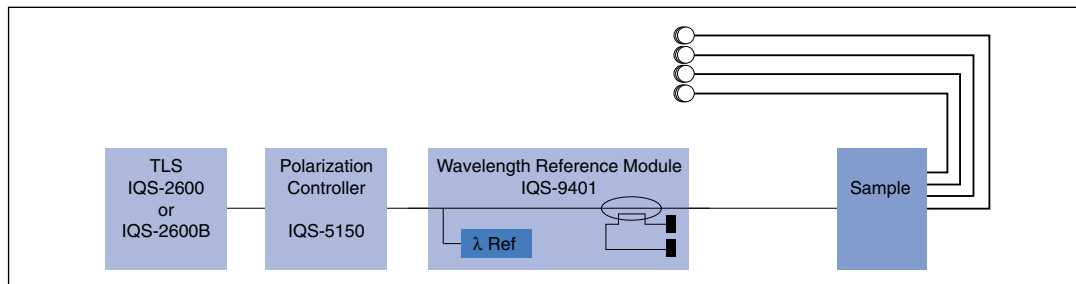

Figure 5. ORL setup with sample used as DEMUX

As a demultiplexer, the sample was tested, as shown in Figure 5, with a non-reflective termination on each of the sample outputs. Results are shown in Figure 6.

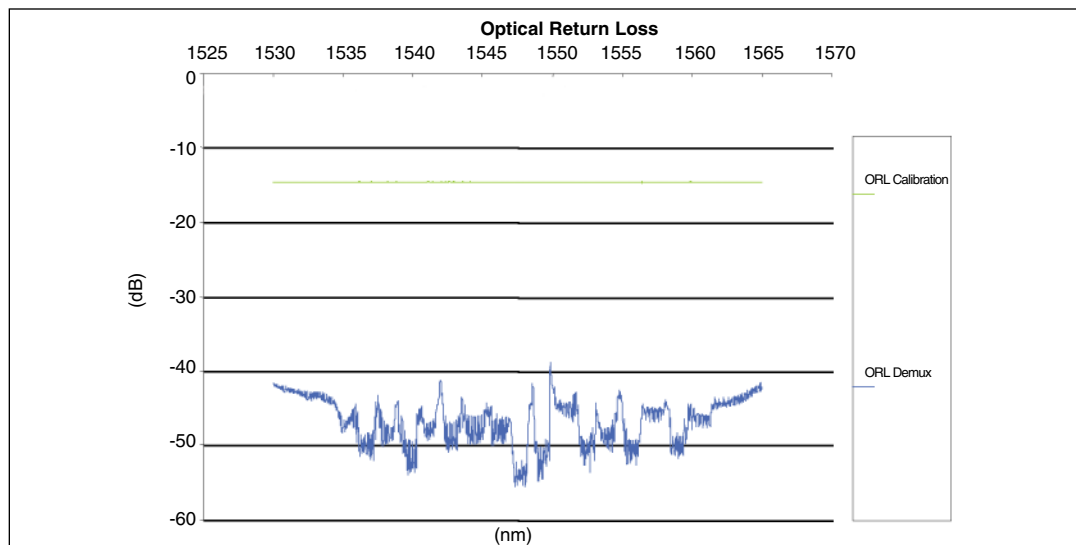

Figure 6. Results for DEMUX setup with non-reflective termination

Note: The ORL calibration (~ 14.7 dB) curve shown above is for reference purposes only.

It is obvious from the data that there is significant ORL structure in the device. The ripple in the ORL measurement is most likely caused by interference resulting from multiple reflections inside the device. It is worth noting that the coherent length of the tunable laser is ~ 20 cm to 30 cm.

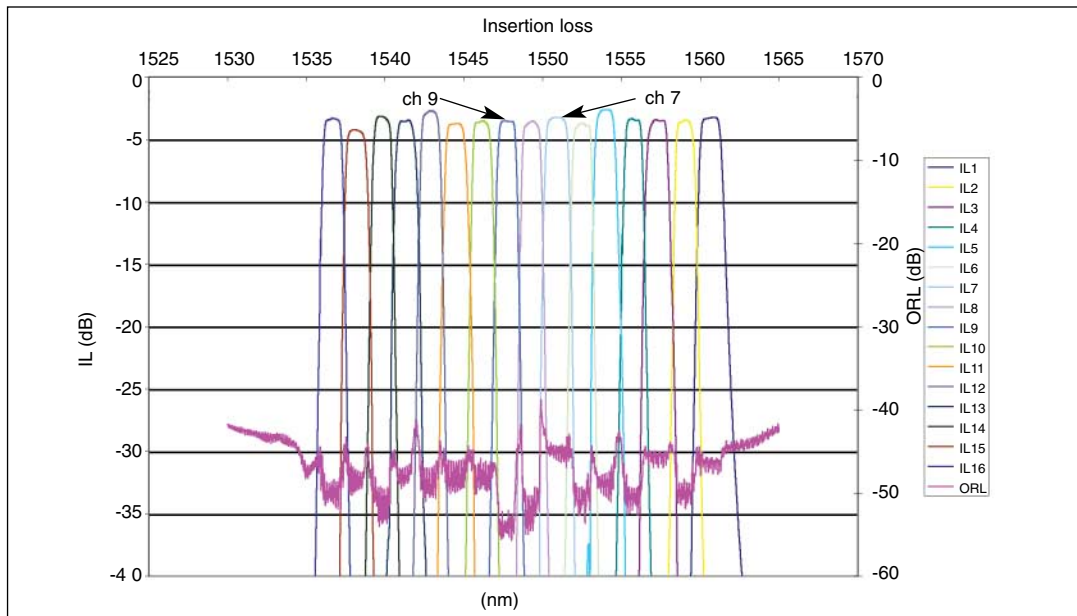

Figure 6. ORL structure vs. device channels

Figure 6 shows the ORL structure in relation to the device channels, where the maximum reflections are in the channel transition zones. In addition, the ORL differs for each channel and a variation of > 10 dB is observed in channel 9 and channel 7, for example, both of which are very close to 1550 nm.

Multiplexer ORL Results

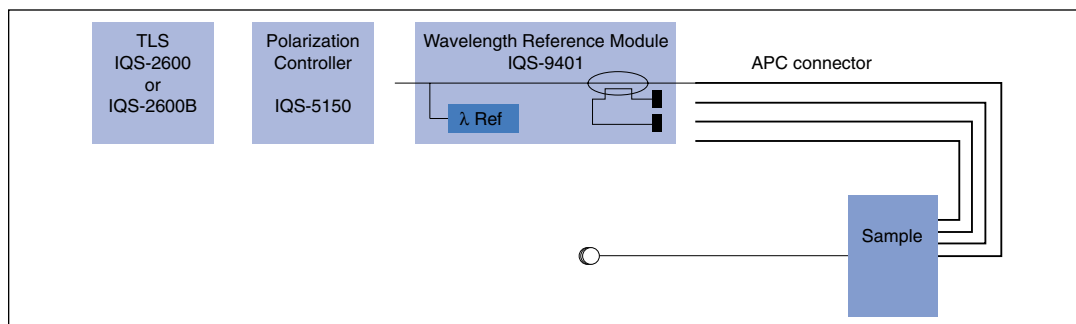

Figure 7. ORL setup with sample used as MUX

As a multiplexer, the sample was tested, as shown in Figure 7, with a non-reflective termination on the common port. The results are shown in Figure 8.

Again, there is considerable structure and variation within the measurements, notably on channel 16. A measurement of one of the APC connectors was taken and is also shown in the data. A hybrid FC/APC-SC/APC adapter was used, explaining the less than optimal ORL (~ 57 dB) of the connector pair.

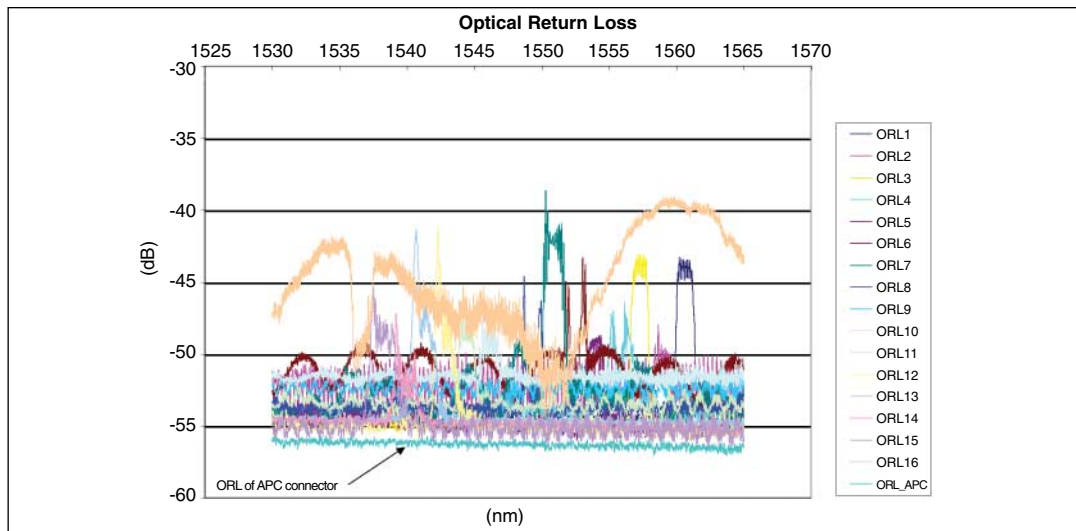

Figure 8. Results for MUX with non-reflective termination on common port

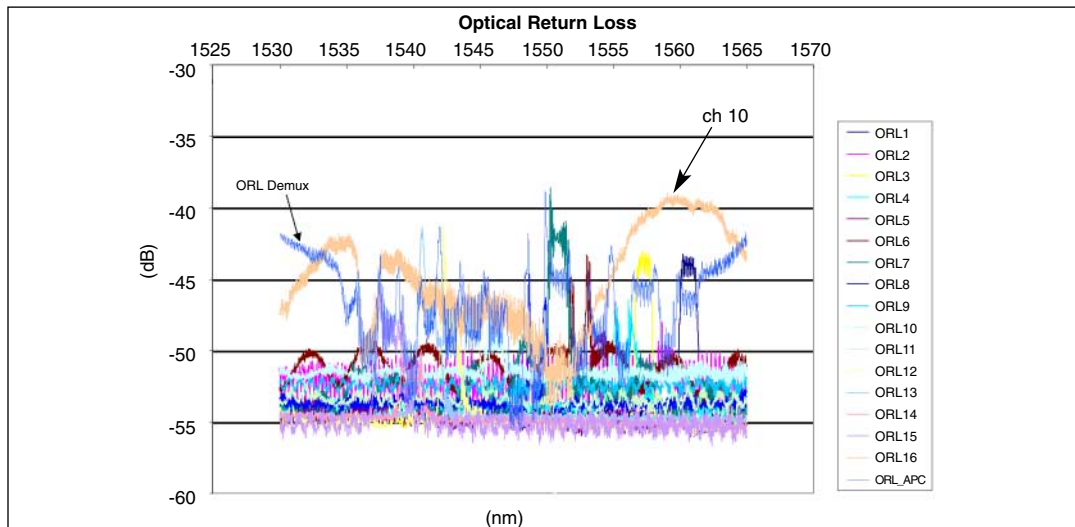

Figure 9. Comparison between MUX and DEMUX measurements

Conclusion and Recommendations

Based on the significant structure in the ORL data for the device, it would be meaningless to test the component at nominal wavelengths such as 1550 nm, for example. It is, therefore, necessary to use a spectral measurement system based on either a tunable laser or OSA. Since it would be difficult to obtain sufficient dynamic range with an OSA, we are recommending the use of a medium-coherence tunable laser like the IQS-2600 or IQS-2600B product series, either with a dedicated return loss meter (IQS-3200) or within the IQS-12004B test system.

Corporate Headquarters > 400 Godin Avenue, Vanier (Quebec) G1M 2K2 CANADA | Tel.: 1 418 683-0211 | Fax: 1 418 683-2170 | info@exfo.com

Toll-free: 1 800 663-3936 (USA and Canada) | www.exfo.com

EXFO America	4275 Kellway Circle, Suite 122	Addison, TX 75001 USA	Tel.: 1 800 663-3936	Fax: 1 972 836-0164
EXFO Europe	Le Dynasteur, 10/12 rue Andras Beck	92366 Meudon la Forêt Cedex FRANCE	Tel.: +33.1.40.83.85.85	Fax: +33.1.40.83.04.42
EXFO Asia-Pacific	151 Chin Swee Road, #03-29 Manhattan House	SINGAPORE 169876	Tel.: +65 6333 8241	Fax: +65 6333 8242
EXFO China	Beijing New Century Hotel Office Tower Room 1754-1755 No. 6 Southem Capital Gym Road	Beijing 100044 P. R. CHINA	Tel.: +86 (10) 6849 2738	Fax: +86 (10) 6849 2662